

Model: MIPM-17HBT
17" High brightness Marine Industrial Panel Monitor , with Touch screen
(VGA +DVI + S-Video + AV input)

Main Feature

- Dimming knob control backlight brightness from nearly 0% to 100%
- Front IP65 aluminum bezel with powder coating
- Wide range DC8-30V power input with Lockable connector (AC Power in option)
- Front hardness AR glass protection (touch option)
- 1000cd/m2 brightness
- Build in 2 x 2 watts stereo speaker
- IP65 Front OSD Design , Ease for use front OSD control
- Enhanced anti-shock and vibration resistance design
- Meet standard VESA hole (75 x 75mm and 100 x 100mm)
- Panel (Flush) mount ,VESA and bracket mount



Specification	
Product Model	MIPM-17HBT
LCD Panel	Display Type : 17" SXGA TFT LCD Pixel Number : 1280 x 1024 Pixel Pitch(RGB) : 0.264 x 0.264 Display area :337.92(H) x270.336(V) mm Contrast Ratio : 800: 1 Light Intensity : 1000 cd/m2 Viewable Angles (L/R,U/D) : 80/80 , 80/80 Max Colors : 16.7M Response time : 5ms Power consumption : 50 W LCD MTBF : 50.000hrs
Mechanical and Environmental	Power Control : Front Power On/Off via Front Button VR Control : Front VR Brightness Knob Control OSD control : Front on screen display control Mounting : Panel (Flush) mount ,VESA and bracket mount Dimensions (WxHxD) : 408 x 345 x 55 mm Weight : Net 8kg Operating Temperature : 0 °C to 50 °C Storage temperature : -20 °C to 60 °C Storage humidity : 10% to 90%non-condensing Anti-Vibration : 5Hz-500 HZ / 1G PTP Anti-Shock : 15G / Peak(11m sec)
Available Options	Touch Screen : Resistive Type / Capacitive / IR / SAW AC Power input : 100 to 240 V AC Bracket mount : Stand and roof mount / Rotary bracket / Sun Visor bracket
Input Signals	RGB Signal : D-SUB 15P connector(female) Composite Audio/Video : RCA plug S-Video Signal : S-Video (SVHS) plug DVI-D Signal : DVI-D input 24pin connector

	DC Power Signal : 5.8mm DC Jack with Lockable AC Power Signal (Option) : Standard IEC Inlet Touch Screen RS-232 (Optional) : D-SUB 9P connector (female) Touch Screen USB (Optional) : USB-A connector (female)
Power Specifications	DC Input : 8-30V DC to DC power input with Lockable connector
Certification and Approvals	CE/FCC/Rohs Certification: IEC60945

Ordering Information

MIPM-17HBT	17" High brightness Marine Industrial Panel Monitor, with Touch screen (VGA +DVI + S-Video + AV input)
Optional: SR-BKT	Mounting bracket for stand and roof mount
Optional: RT-BKT	Rotary bracket
Optional: SV-BKT	Sun Visor bracket

Mechanical Drawing with Robust Bracket (options)

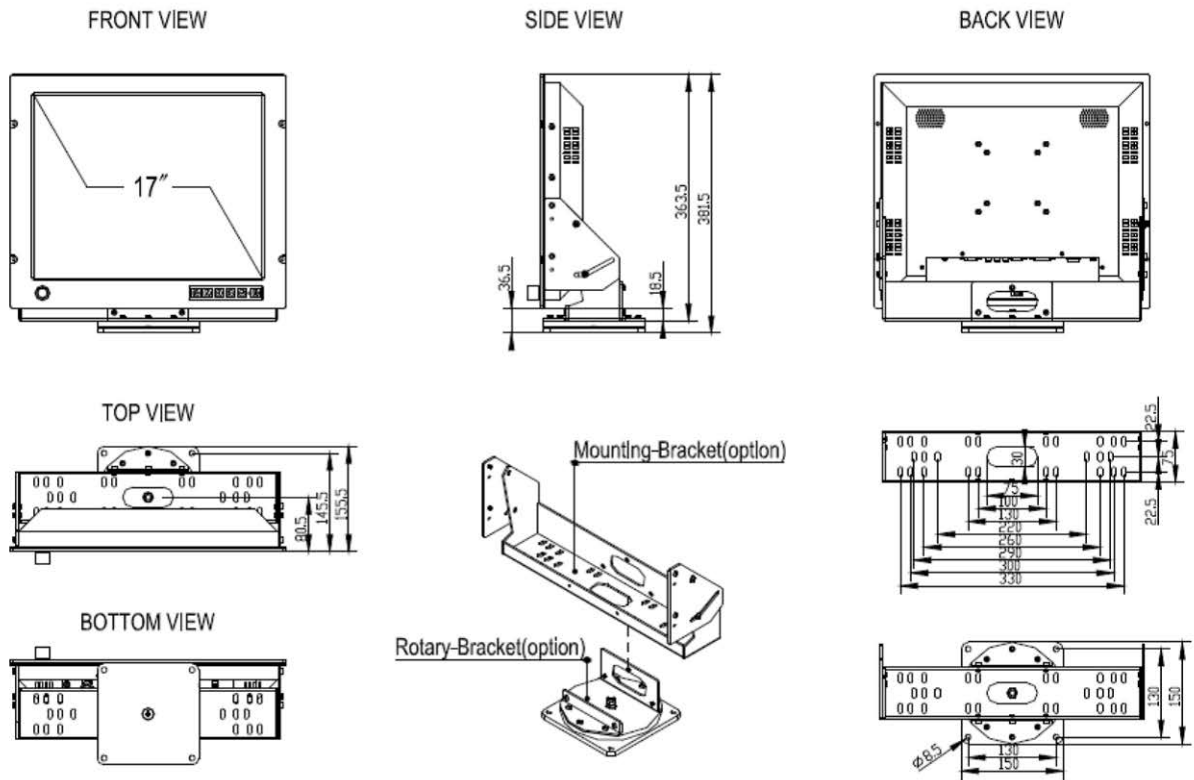

STAND MOUNT Bracket

Unit : mm

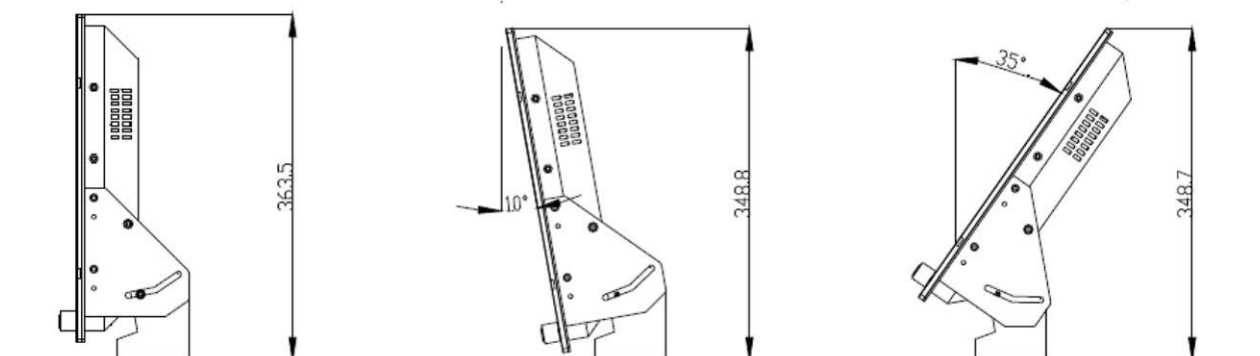

MARK	DATE	UPDATE DESCRIPTION	SIGN	APPROVER
△				

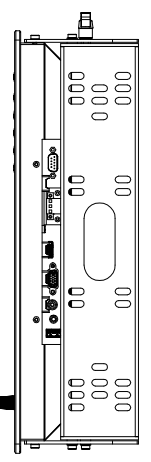
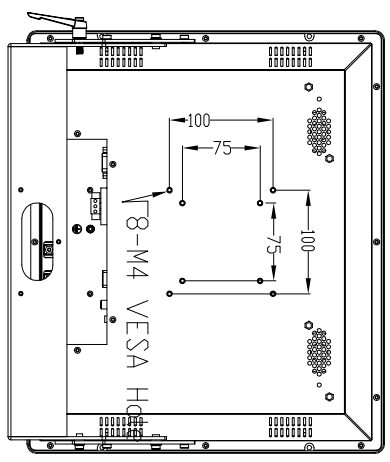
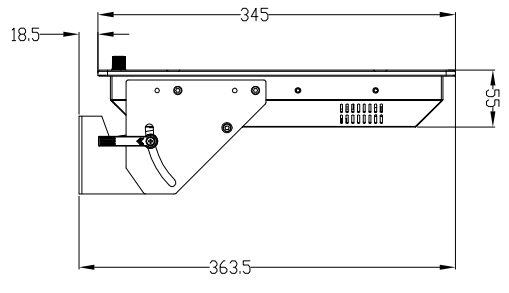
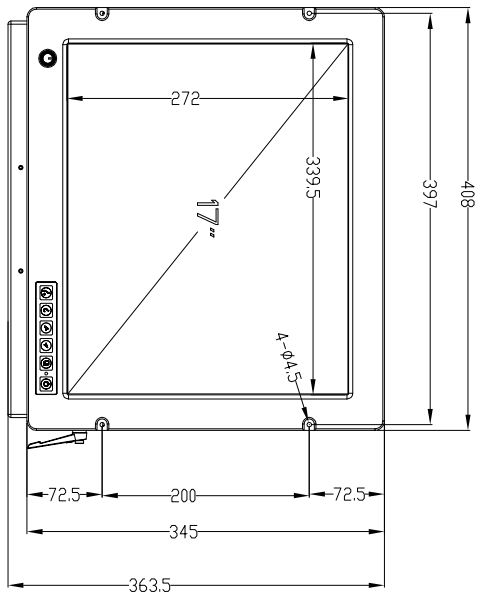
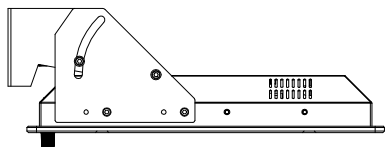
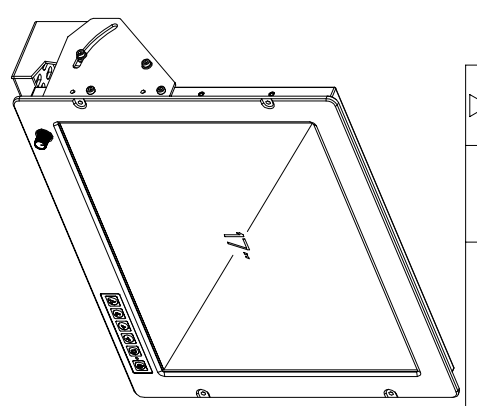
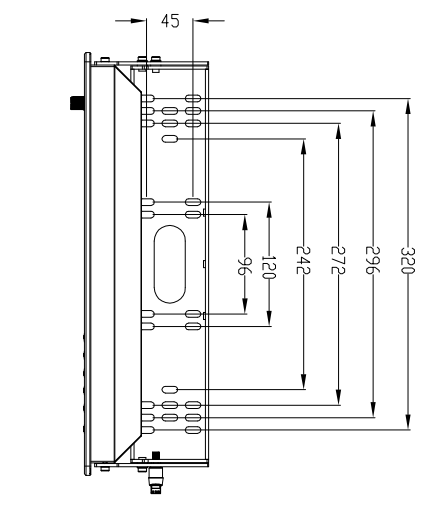

CUT OUT DIMENSION (386×323mm) UNIT:mm

* Note: this is a simplified drawing and some components are not marked in detail. Please contact our sales representative if you need further product information.

DA Vision Pte Ltd

Ver.	A0	FINISHING		
Qty	1	MATERIAL		
SELECT V	V	EXTRA		
DIM TOL	A	B	C	D
-8	±0.03	±0.05	±0.10	±0.20
8-25	±0.05	±0.08	±0.20	±0.30
25-80	±0.08	±0.12	±0.30	±0.40
80-250	±0.12	±0.20	±0.40	±0.50
250+	±0.20	±0.30	±0.50	±0.60
ANGLE TOL	±0.2°	±0.3°	±0.4°	±0.5°
3RD ANGLES				
TITLE		MIPM-17-ASSY		
DRAWING NO.		MIPM-17-3D3V.DWG		
MODEL NO.		MIPM-17		
DATE		16-Dec-17		
PART NO.				
SCALE		1:1		
SIZE		A3		
SHEET		1 OF 1		