

**Model: MIPM-15HB**  
**15" High brightness Marine Industrial Panel Monitor (VGA +DVI + S-Video + AV input)**

### Main Feature

- Dimming knob control backlight brightness from nearly 0% to 100%
- Front IP65 aluminum bezel with powder coating
- Wide range DC8-30V power input with Lockable connector(AC Power in option)
- Front hardness AR glass protection (touch option)
- 1600cd/m2 brightness
- Build in 2 x 2 watts stereo speaker
- IP65 Front OSD Design , Ease for use front OSD control
- Enhanced anti-shock and vibration resistance design
- Meet standard VESA hole ( 75 x 75mm and 100 x 100mm)
- Panel ( Flush ) mount ,VESA and bracket mount

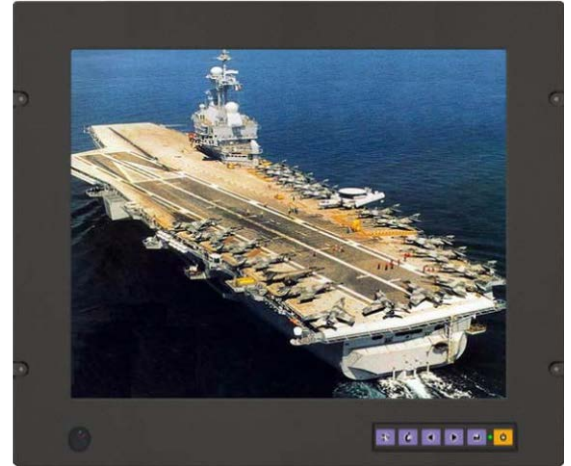

Specification	
Product Model	MIPM-15HB
LCD Panel	Display Type : 15" XGA TFT LCD Screen resolution (Pixels) : 1024 × 768 Brightness : 1600cd/m2 Contrast Ratio : 600 : 1 Pixel Size : 0.297*0.297 Max Color : 16.7M Viewing angle(L/R,T/B) : 80/80, 80/80 Response Time : 8 ms
Mechanical and Environmental	Power Control : Front Power On/Off via Front Button VR Control : Front VR Brightness Knob Control OSD control : Front on screen display control Mounting : Panel ( Flush ) mount ,VESA and bracket mount Dimensions (WxHxD) : 375 x 300 x 58 mm Weight : Net 6kg Operating Temperature : 0 °C to 50 °C Storage temperature : -20 °C to 60 °C Storage humidity : 10% to 90%non-condensing Anti-Vibration : 5Hz-500 HZ / 1G PTP Anti-Shock : 15G / Peak( 11m sec)
Available Options	AC Power input : 100 to 240 V AC Bracket mount : Stand and roof mount / Rotary bracket / Sun Visor bracket
Input Signals	RGB Signal : D-SUB 15P connector(female) Composite Audio/Video : RCA plug S-Video Signal : S-Video (SVHS) plug DVI-D Signal : DVI-D input 24pin connector DC Power Signal : 5.8mm DC Jack with Lockable AC Power Signal (Option) : Standard IEC Inlet
Power Specifications	DC Input : 8-30V DC to DC power input with Lockable connector

Certification and Approvals	CE/FCC/Rohs Certification: IEC60945
-----------------------------	--

## Ordering Information

MIPM-15HB	15" High brightness Marine Industrial Panel Monitor (VGA +DVI + S-Video + AV input)
Optional: SR-BKT	Mounting bracket for stand and roof mount
Optional: RT-BKT	Rotary bracket
Optional: SV-BKT	Sun Visor bracket

### Mechanical Drawing with Robust Bracket (options)

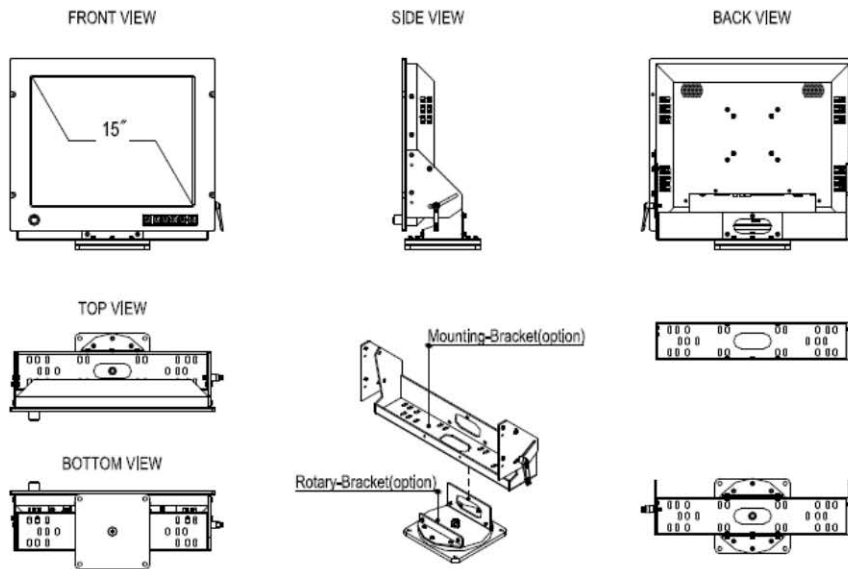

### Stand/Roof Mount + Robust Bracket

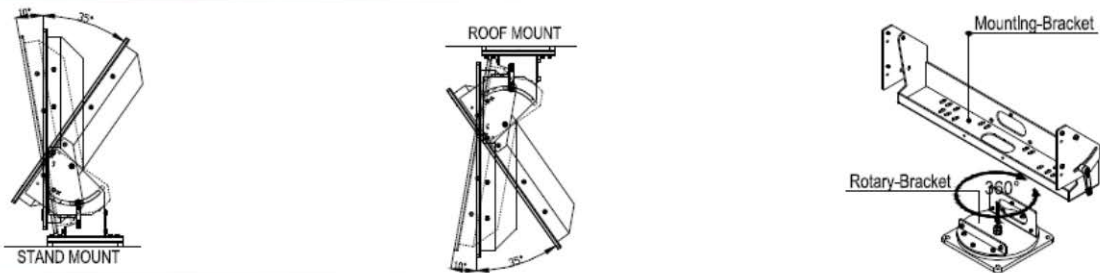

### Sun Visor Bracket

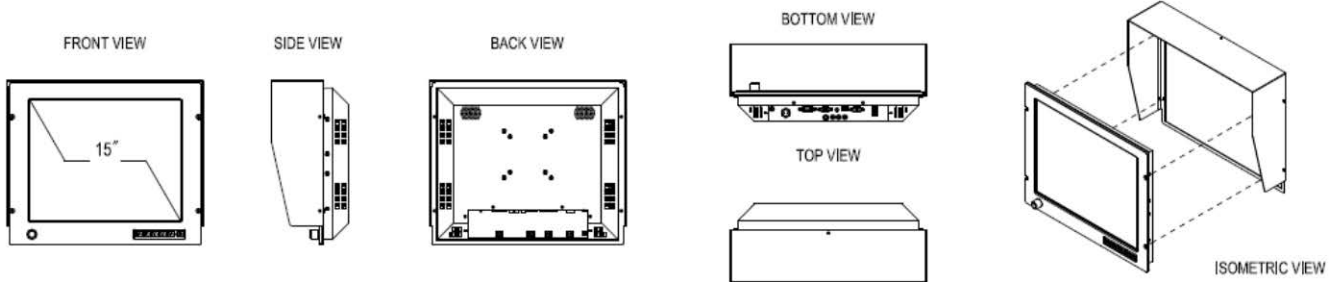

6	7	8
MARK △	DATE	UPDATE DESCRIPTION
		SIGN APPROVER

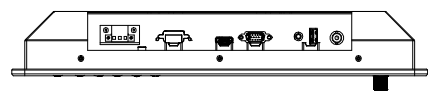
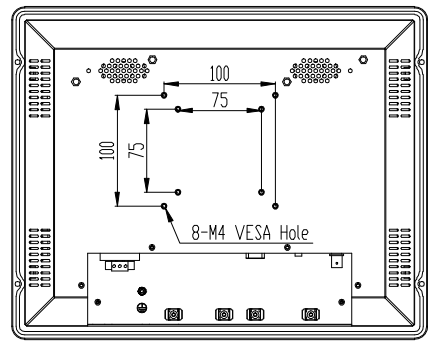
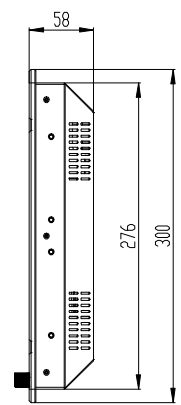
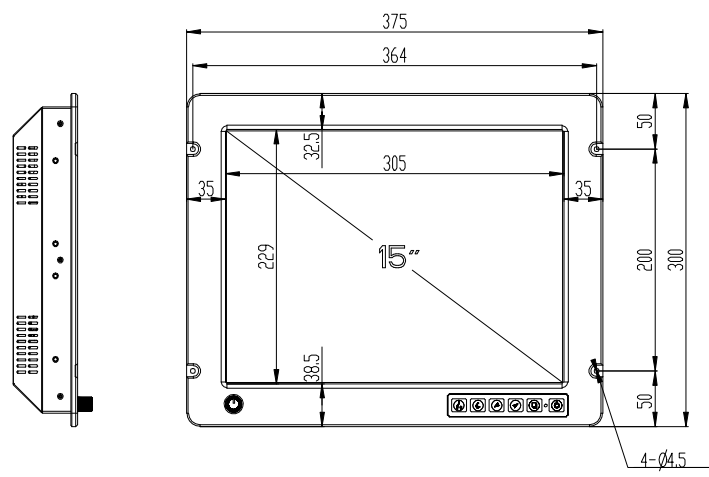
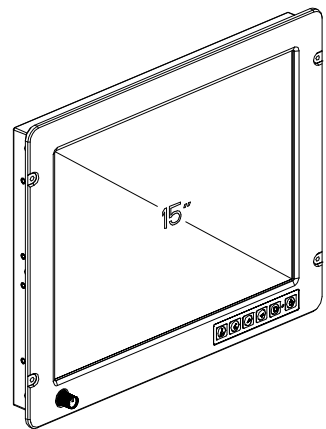
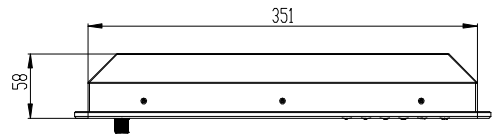

CUT OUT DIMENSION (353x302mm) UNIT:mm

\* Note: this is a simplified drawing and some components are not marked in detail.  
Please contact our sales representative if you need further product information.

Ver.	A0	FINISHING							
Q'ty	1	MATERIAL							
SELECT V	V								
DIM	TOL	A	B	C	D	EXTRA	3RD ANGLE'S	△	
-8	±0.03	±0.05	±0.10	±0.20			APPROVED		TITLE MIPM-15-ASSY
8-25	±0.05	±0.08	±0.20	±0.30			CHECKED		DRAWIN NO. MIPM-15-3D3V.DWG
25-80	±0.08	±0.12	±0.30	±0.40			DESIGNED		MODEL NO. MIPM-15
80-250	±0.12	±0.20	±0.40	±0.50			DATE		SCALE 0.25 UNIT: MM
250-	±0.20	±0.30	±0.50	±0.60					PART NO.
ANGLE TOL	±0.2°	±0.3°	±0.4°	±0.5°					SIZE A3 SHEET: 1 OF 1